



DynaIndustrial



Steel Mill

DynaIndustrial. Experience the Difference.

DynaIndustrial has decades of experience designing custom steel mill equipment. We are well known for extremely robust and high quality equipment.

Customers come to DynaIndustrial to solve complex problems. Since 1976, DynaIndustrial has been successfully solving the steel industry's most challenging problems with innovative engineered designs, turnkey solutions and quality products that **improve safety, increase productivity** and **decrease maintenance downtime.**



Engineering & Custom Design Manufacturing

- 3D solid modeling software
- Finite Element Analysis (FEA)
- Integrated drafting software
- Integrate cost effective processes into our designs.
- Virtual reality software
- Committed to R&D
- Reverse engineering

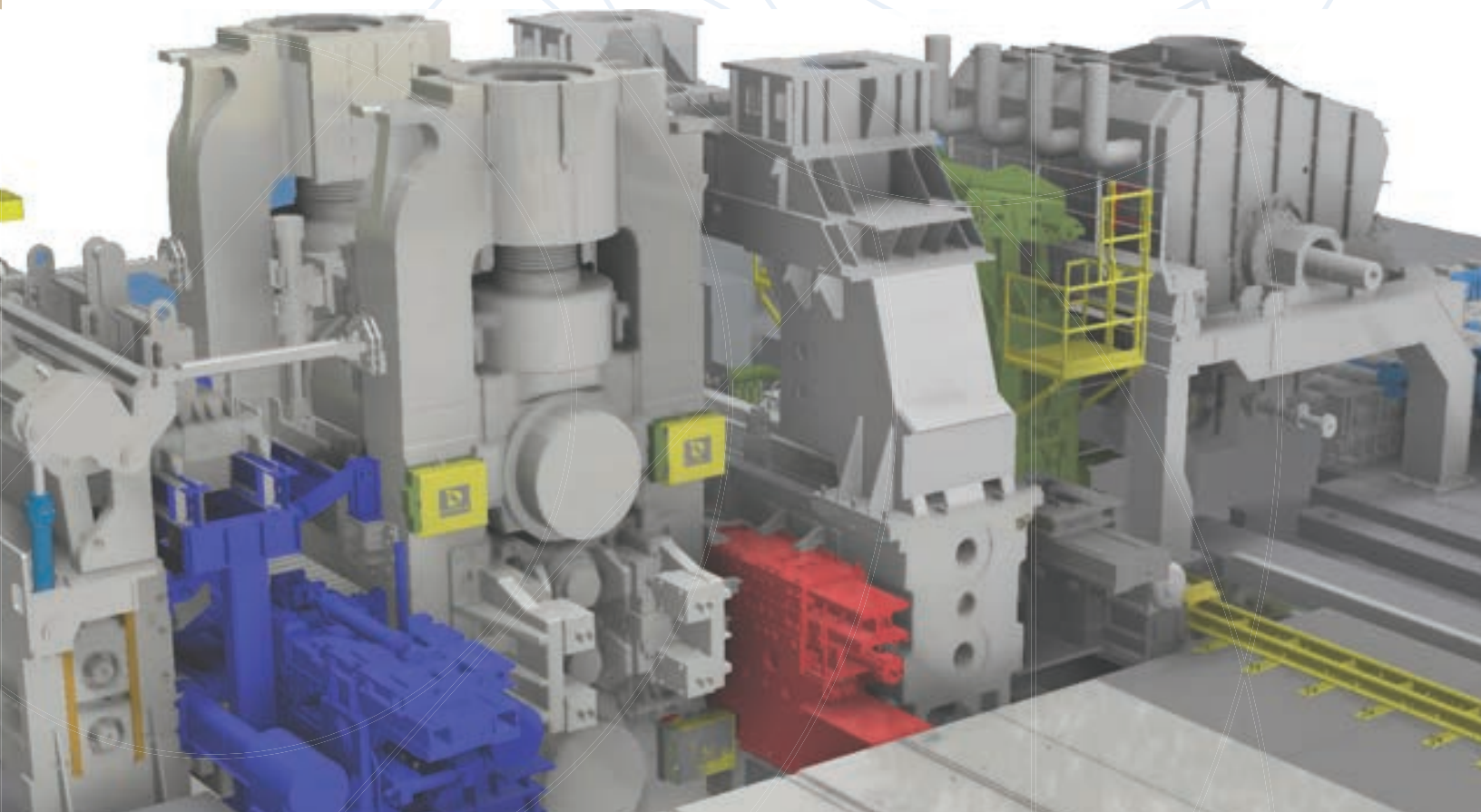

With decades of experience, in-house engineering and state-of-the-art manufacturing, DynaIndustrial provides turnkey solutions to solve the steel mill's most challenging problems.



Steel-Mill Problem

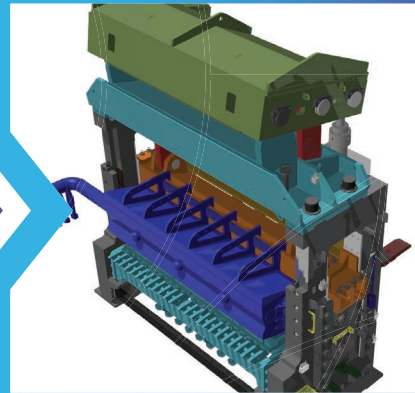

Concept

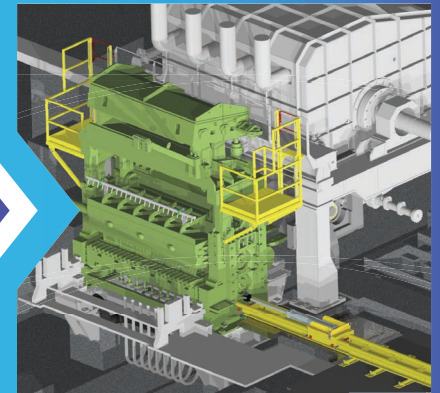

Detailed Design



Test



Ship



Install

From concept to completion, DynaIndustrial works in collaboration with the customer every step of the way.



Drafting



Manufacture



Assembly



Commission



Training



After Sales Support

EAf Platform

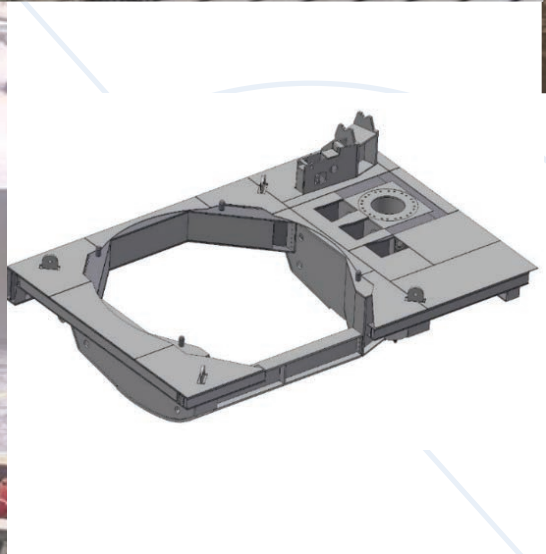

Designed, fabricated, machined and redesigned to eliminate structural failures. Entire platform was modeled and FEA was performed to create a rugged and reliable design.

Ladle & Scrap Transfer Cars

Design and build ladle transfer cars with improvements to allow easier access for maintenance.

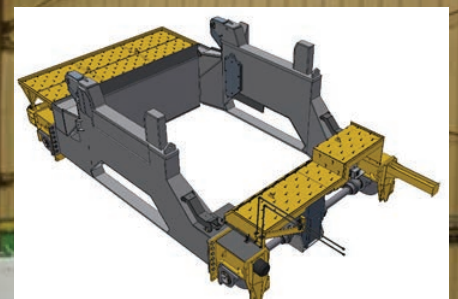
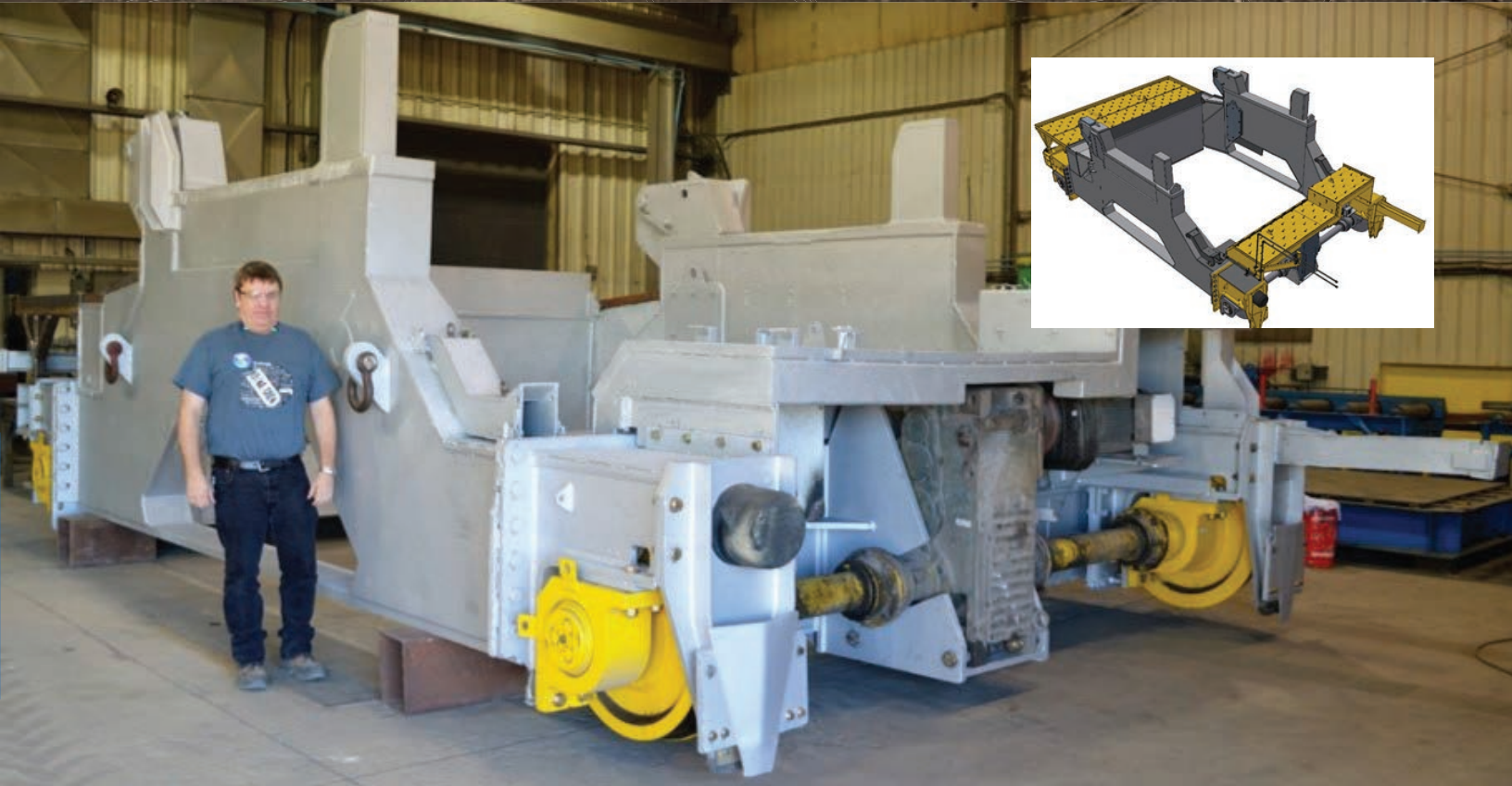

Multi-Purpose Transfer Cars

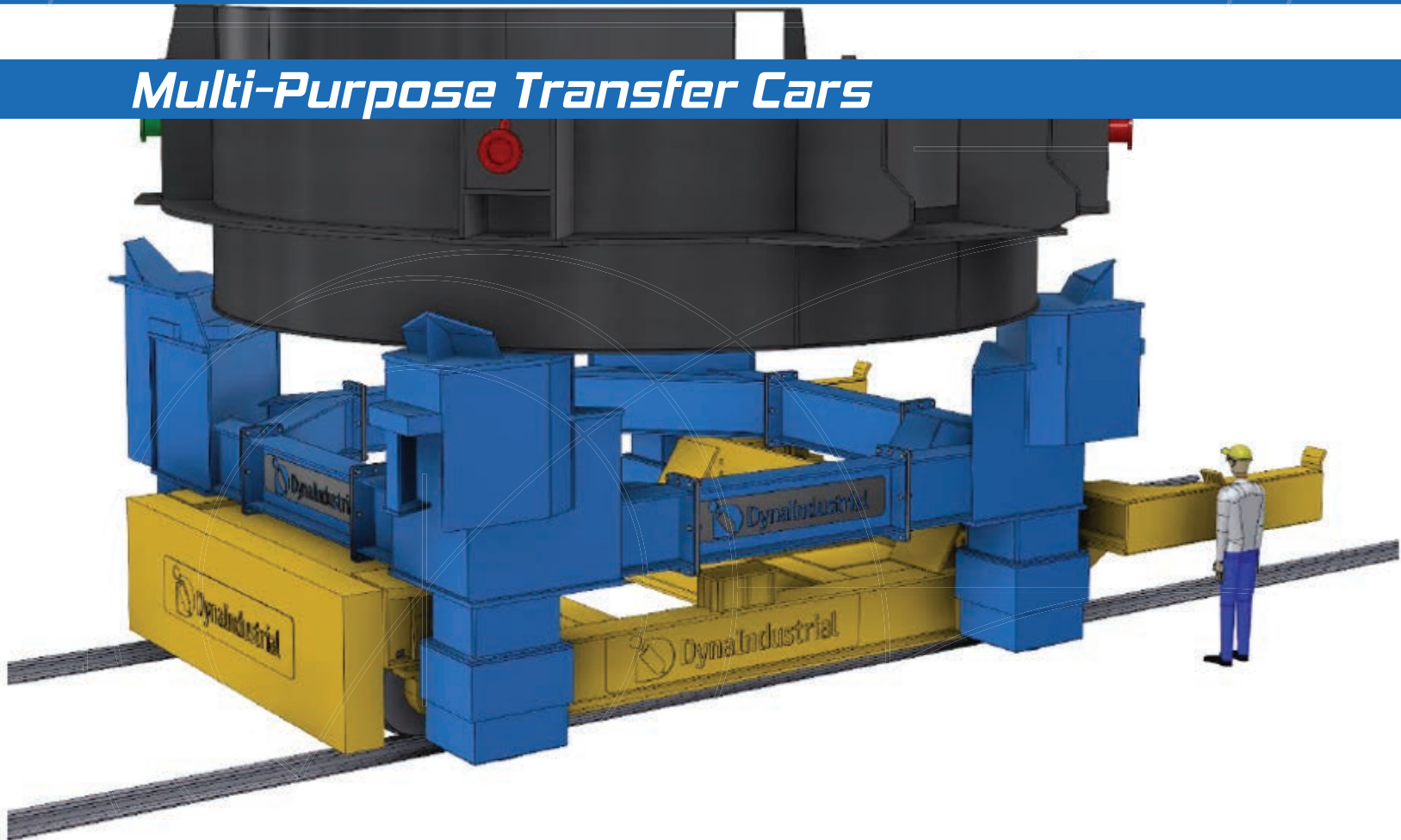

Lower shell and Lifting Pallet on Transfer Car

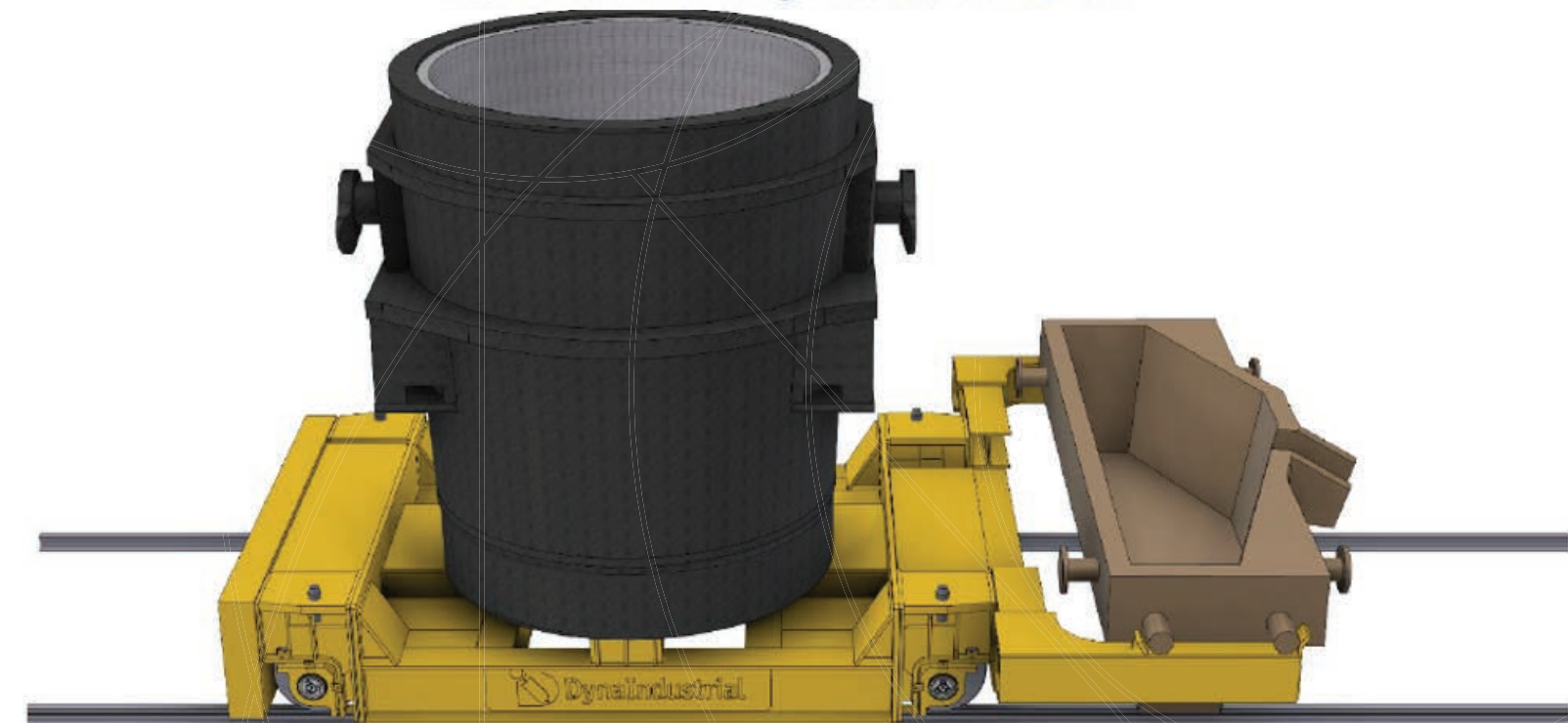

Ladle and Tundish on Transfer Car

Ladles

New builds, repair & modifications (i.e. Add argon stir).



EAF Components

Complete rebuild services of furnace gantry components including gantry pins, mast stems, roller guides, mast stem guides and copper contact pads.

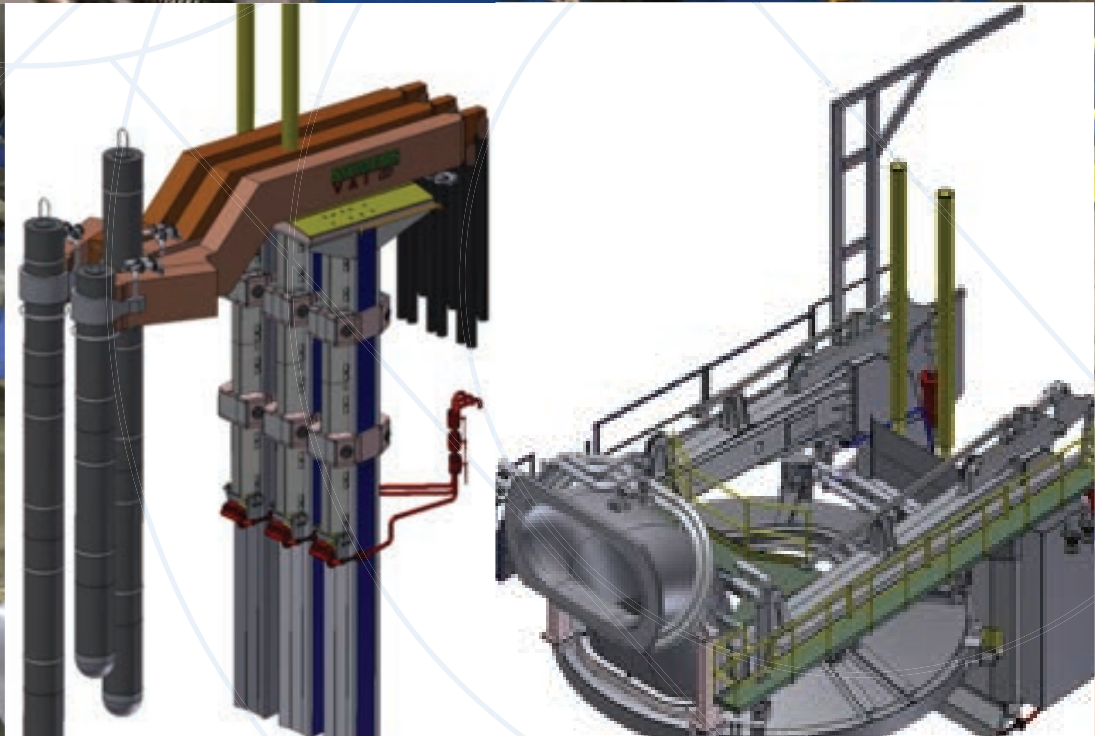

EAJ Mast Stems

Manufactured or rebuild to customer specifications. Failure analysis performed to assist with design improvements to eliminate weld failures and increase cooling to the stem and stool.

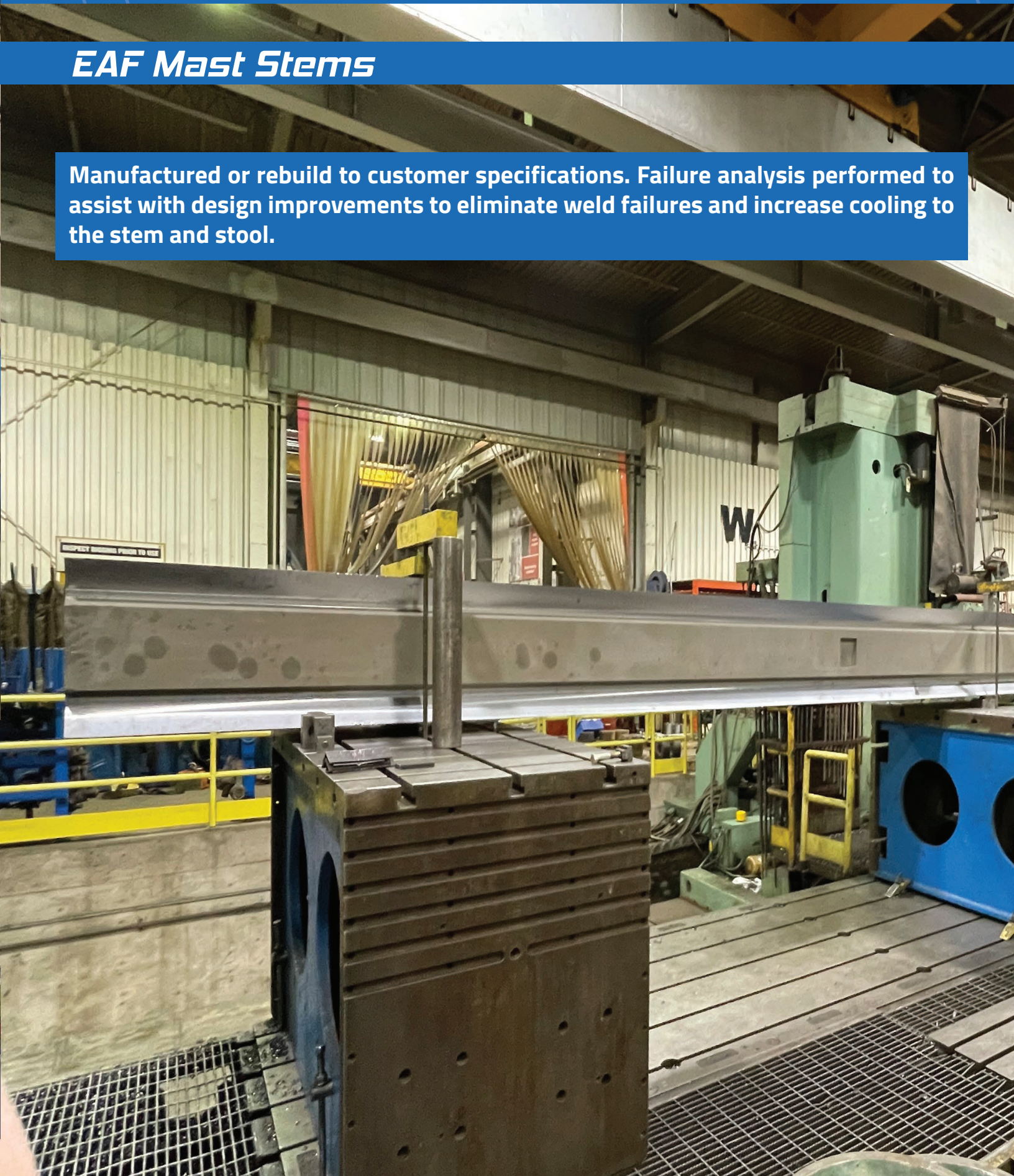

Caster Segments

Complete rebuild service of caster segments including hard surfacing of rolls, remanufacture of components and assembly. Using an existing OEM design, design improvements were made to increase service life, resulting in decreased maintenance cost.

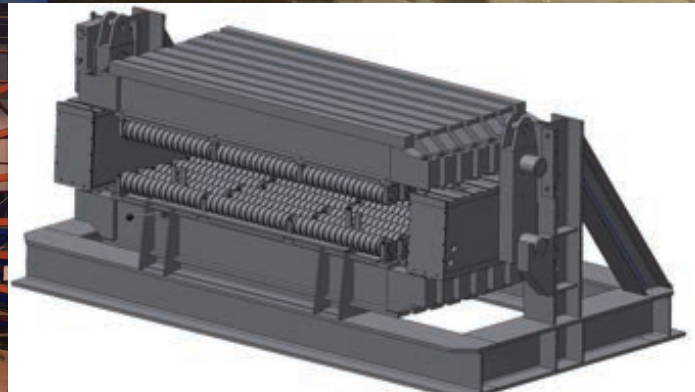
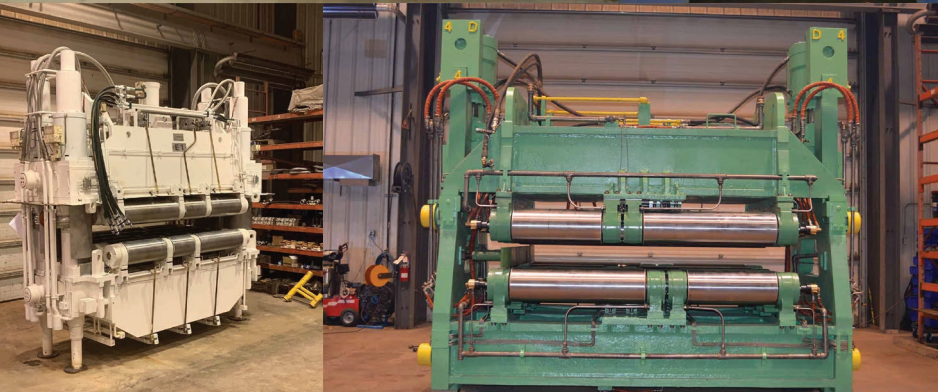

Segment Roll Rebuilding

Roll re-rebuilding cell with dual welders.

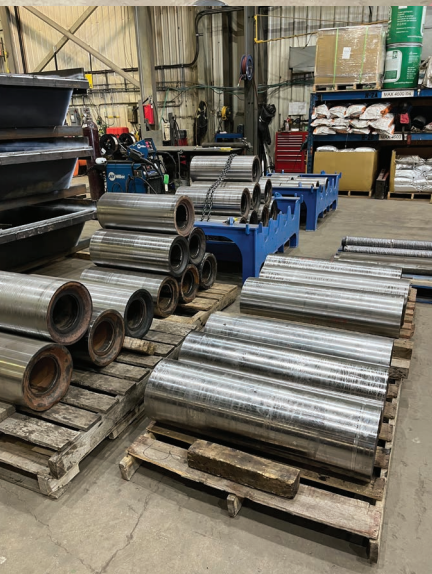

Scrap Buckets

Design & build, modify, repair.



Caster Runout Table & Dekerfer



Billet Table Upgrade

Our customer was having issues with their old table. With increasing capacities, demand for hot charging and lack of lubrication due to environmental we were able to design and build a robust table to accommodate all their needs.

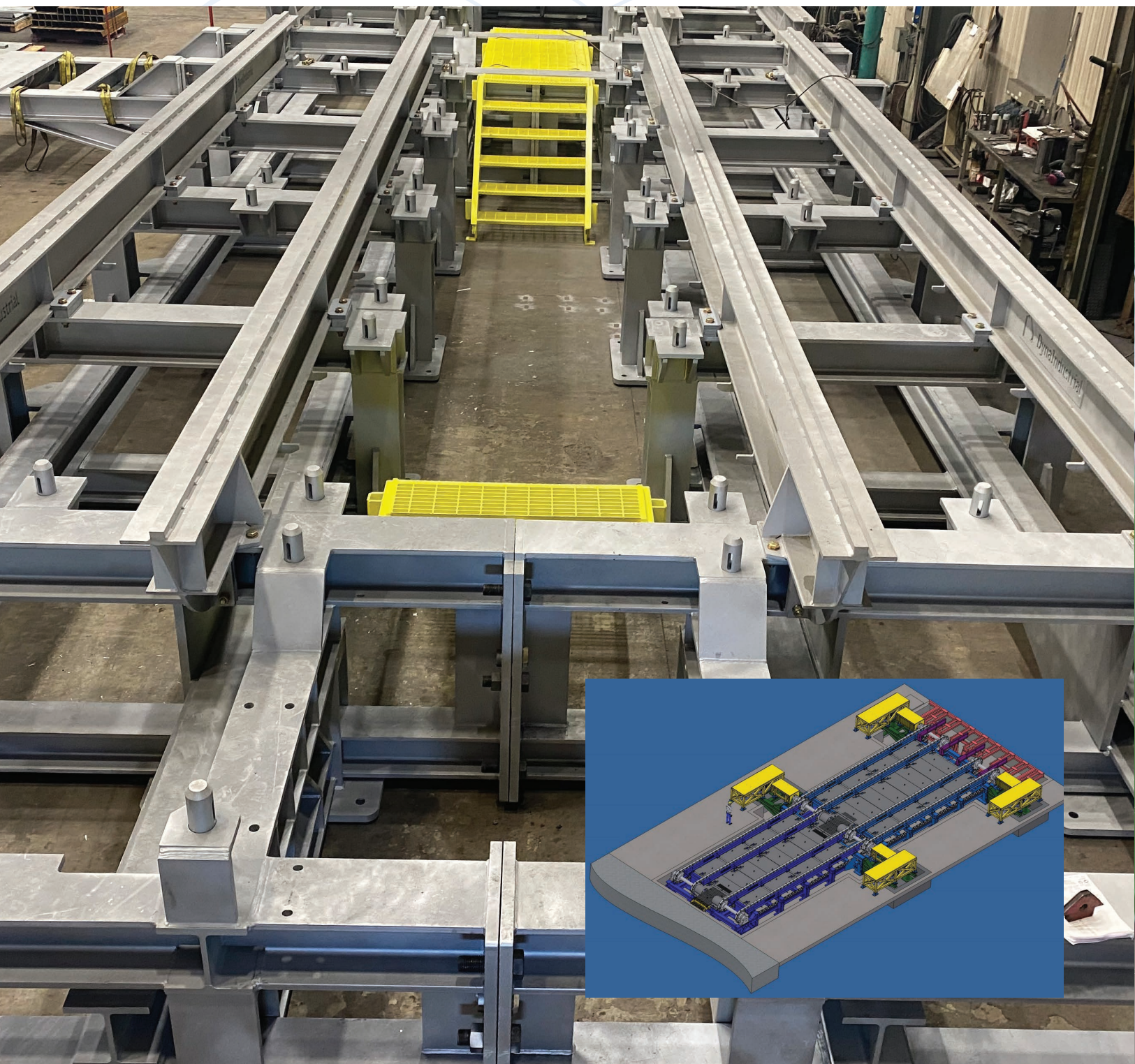

Plate Mill - Entry Guides



Plate Mill - Side Guides



Plate Mill - Pinch Roll Console



Plate Mill - Work Roll Shifting Mechanism

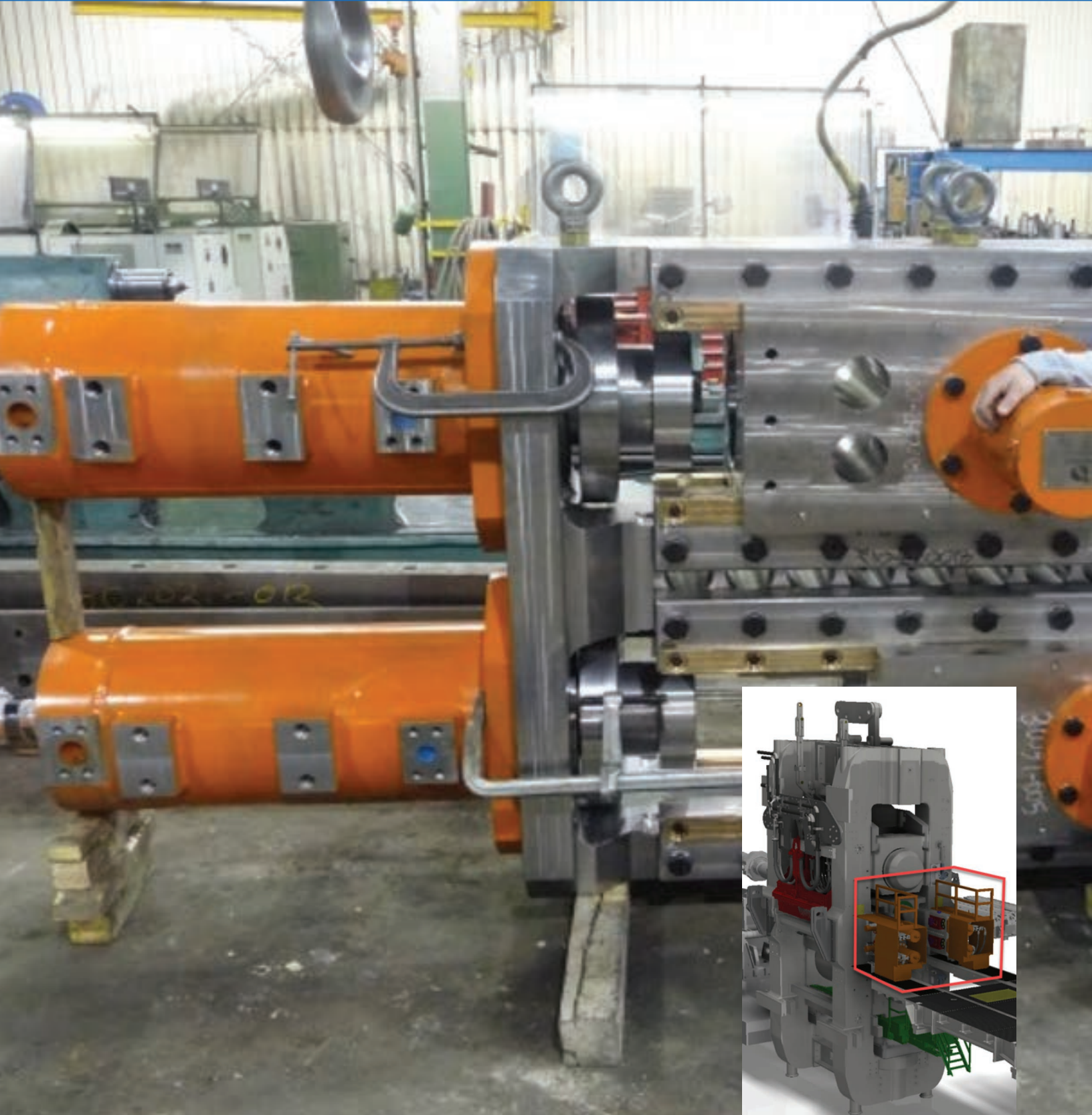

Plate Mill - Top Guide

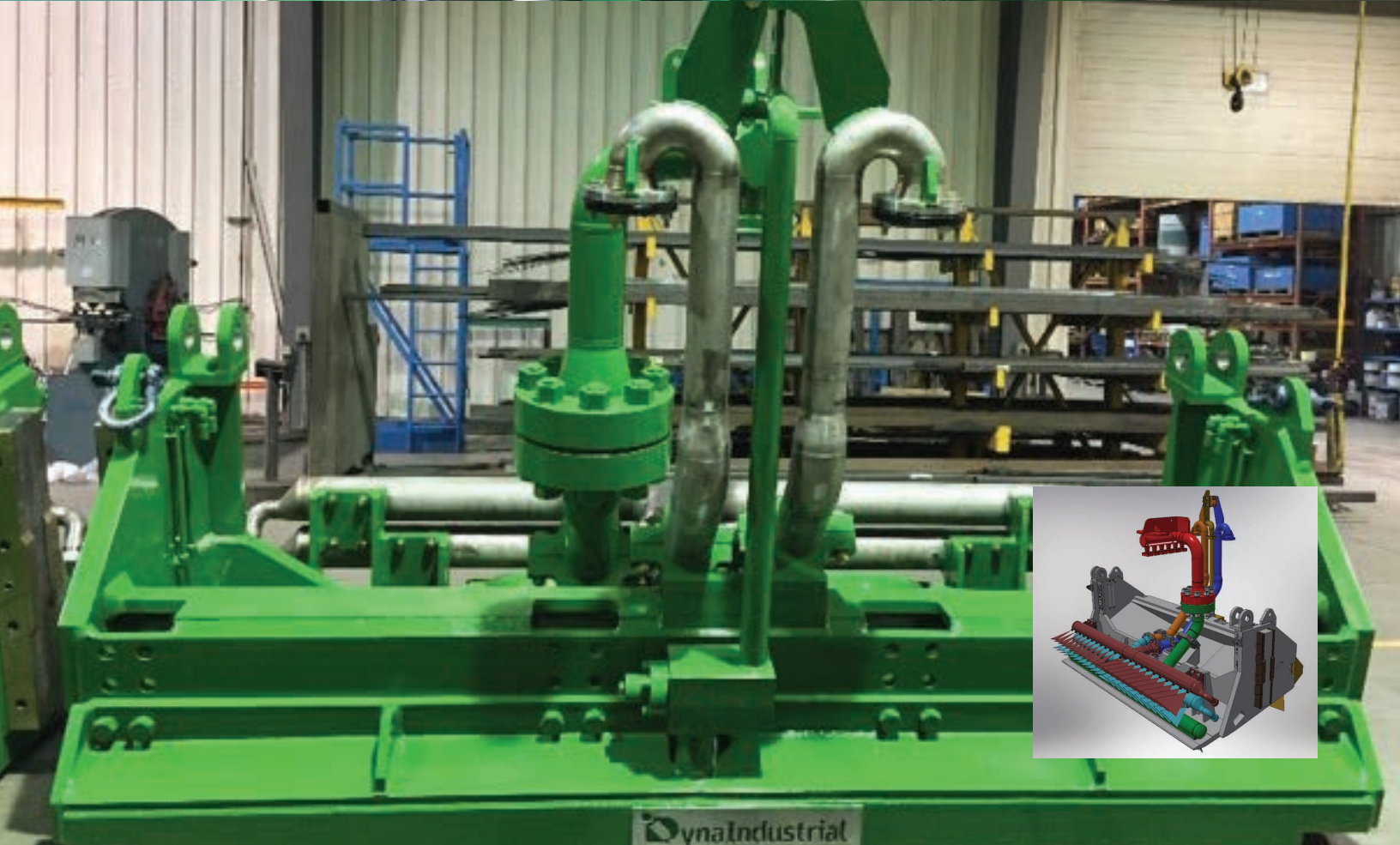
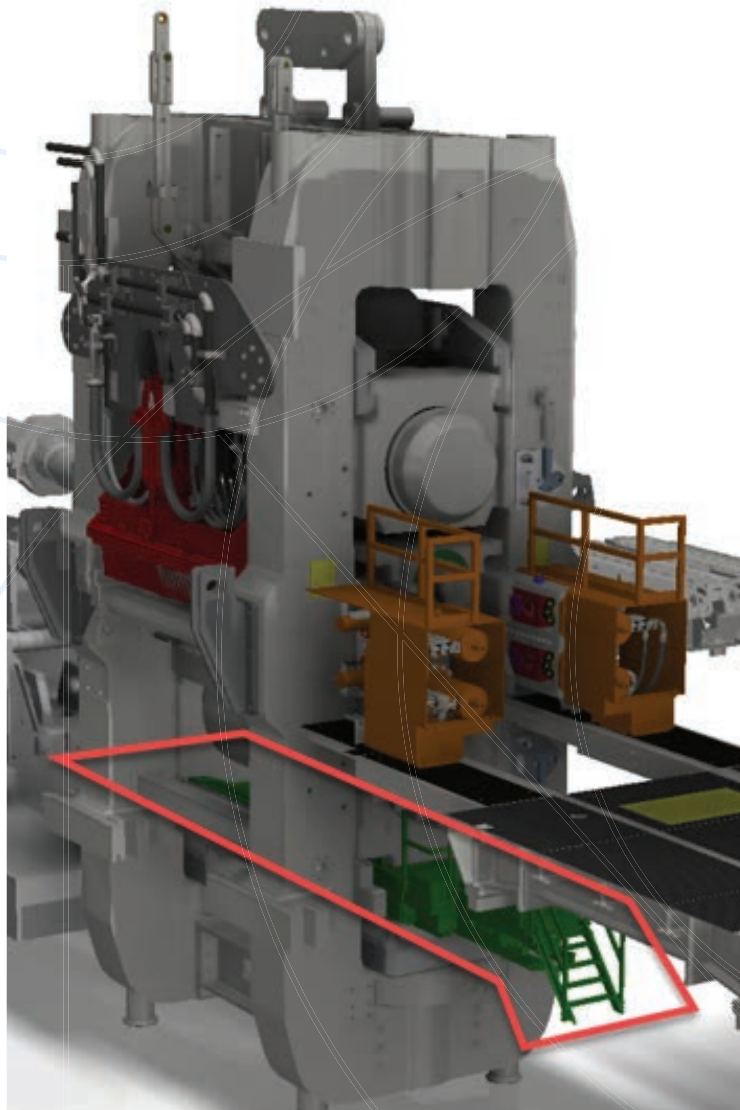
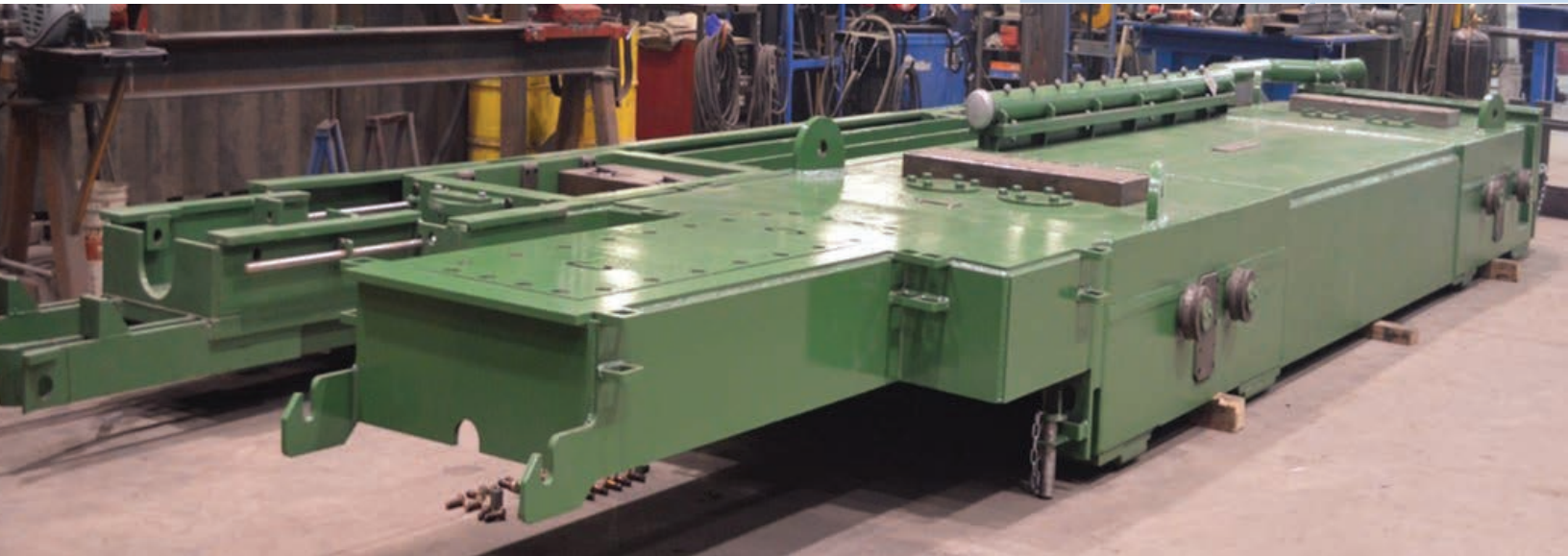

Plate Mill - Step Filler Plate



Coiler Mandrels

Manufacture complete new mandrel assemblies & repair/redesign existing mandrels to increase longevity.

Redesigned the mandrel gearbox to withstand increased forces resulting from higher grade coiled product.

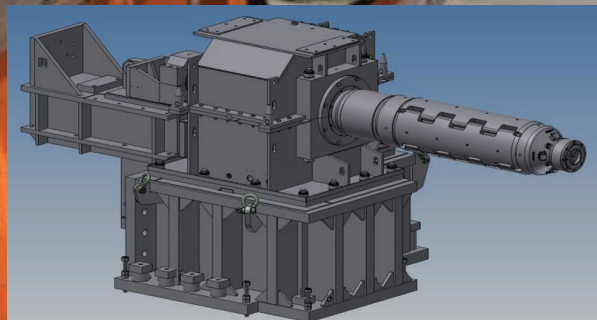



sales@dynaindustrial.com





www.dynaindustrial.com



Locations:

REGINA

 277 Sherwood Road
RM of Sherwood, SK
S4K 0A8

 (306) 359-7088

SASKATOON

 3326 Faithfull Ave
Saskatoon, SK
S7K 8H1

 (306) 933-4303

ALABAMA

 509 Oak Ridge Ct E
Daphne, AL
36526

 (251) 463-9073

TEXAS

 11 Vista Mill Place
The Woodlands TX
77382

 (346) 292-6970